

SERVICE MANUAL

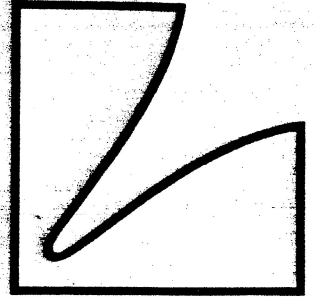

SOLID STATE STEREO
INTEGRATED AMPLIFIER **L-2**

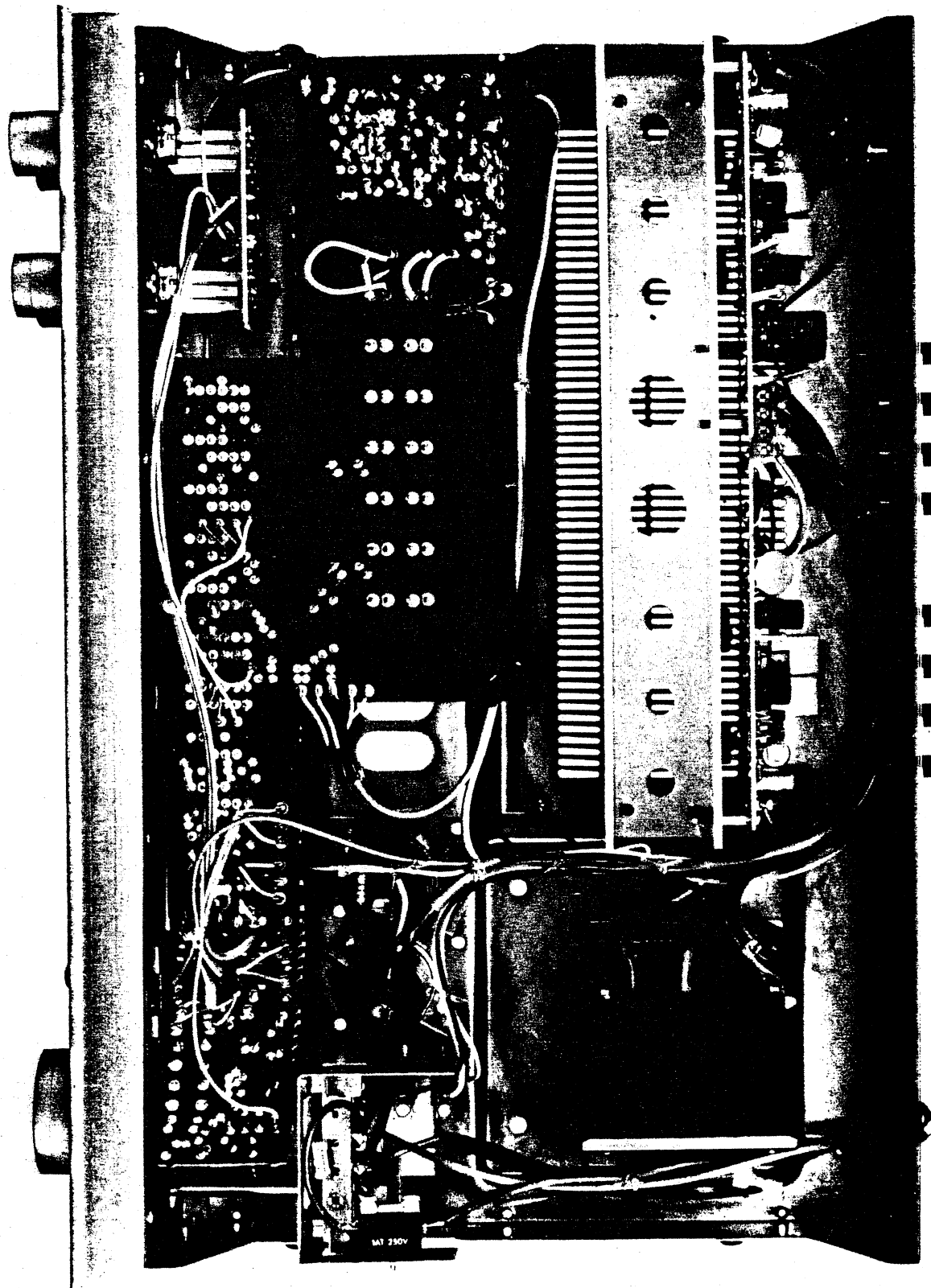



ALIGNMENT PROCEDURE

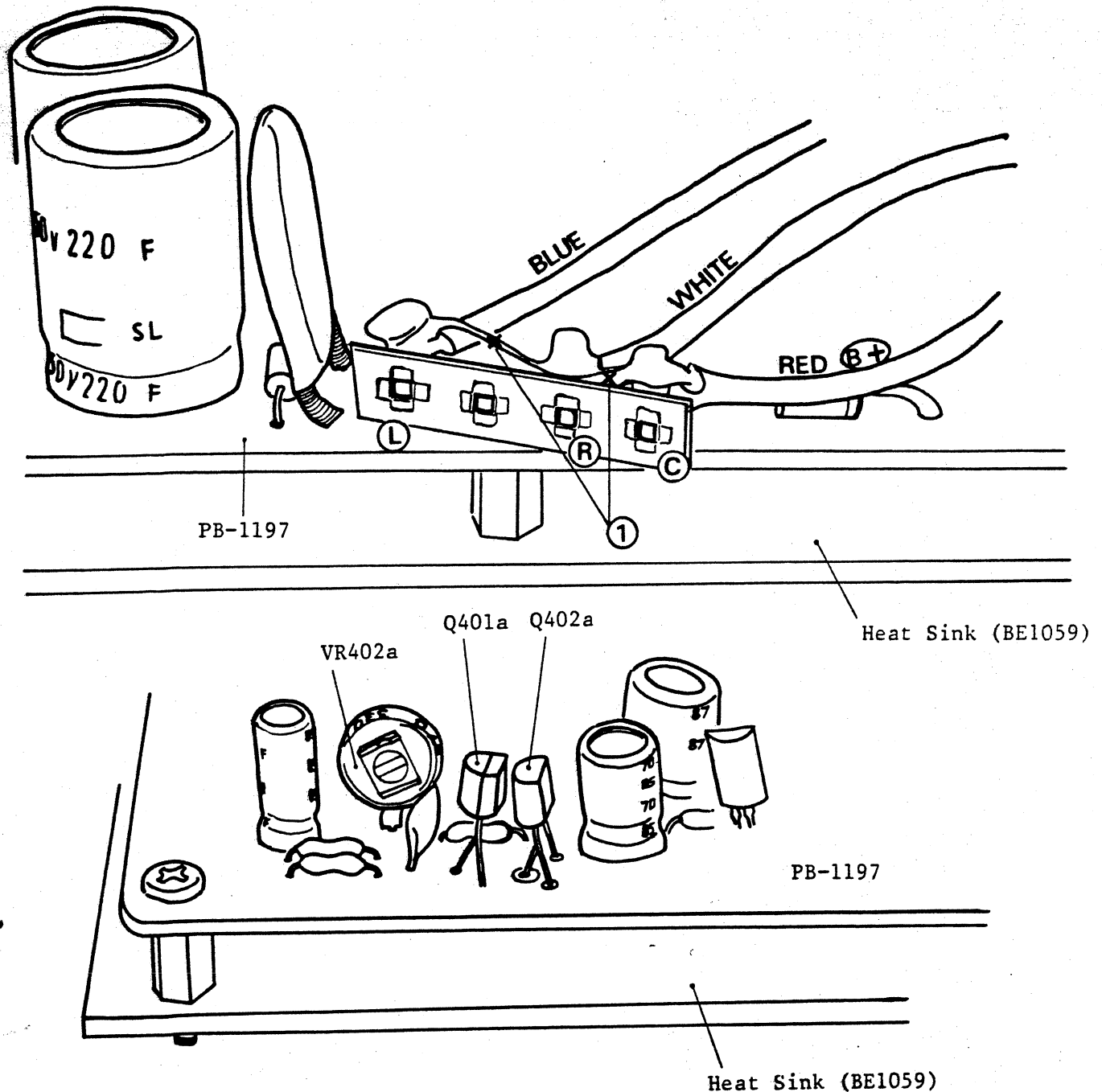

Idle Adjustment

- (1) Cut the jumper lead, as described in the illustration.
- (2) Connect a resistor 10 ohms 1W across (L) and (C).
Connect a DC amperemeter (full scale 250 ÷ 300mA) between (R) and (C). (polarization: (C) +) Adjust VR402b to obtain 50mA reading on the meter. (R-ch idle adjust)
- (3) Disconnect the lead of the resistor connected to (L), and connect it to (R), leaving the lead connected to (C) as it is. Connect a DC amperemeter between (L) and (C). (polarization: (C) +) Adjust VR402a to obtain 50mA reading on the meter. (L-ch idle adjust)
- (4) Connect (C) - (R), and (R) - (L) again by use of jumper leads.
- (5) This adjustment should be done 1 minute after turning the power on.

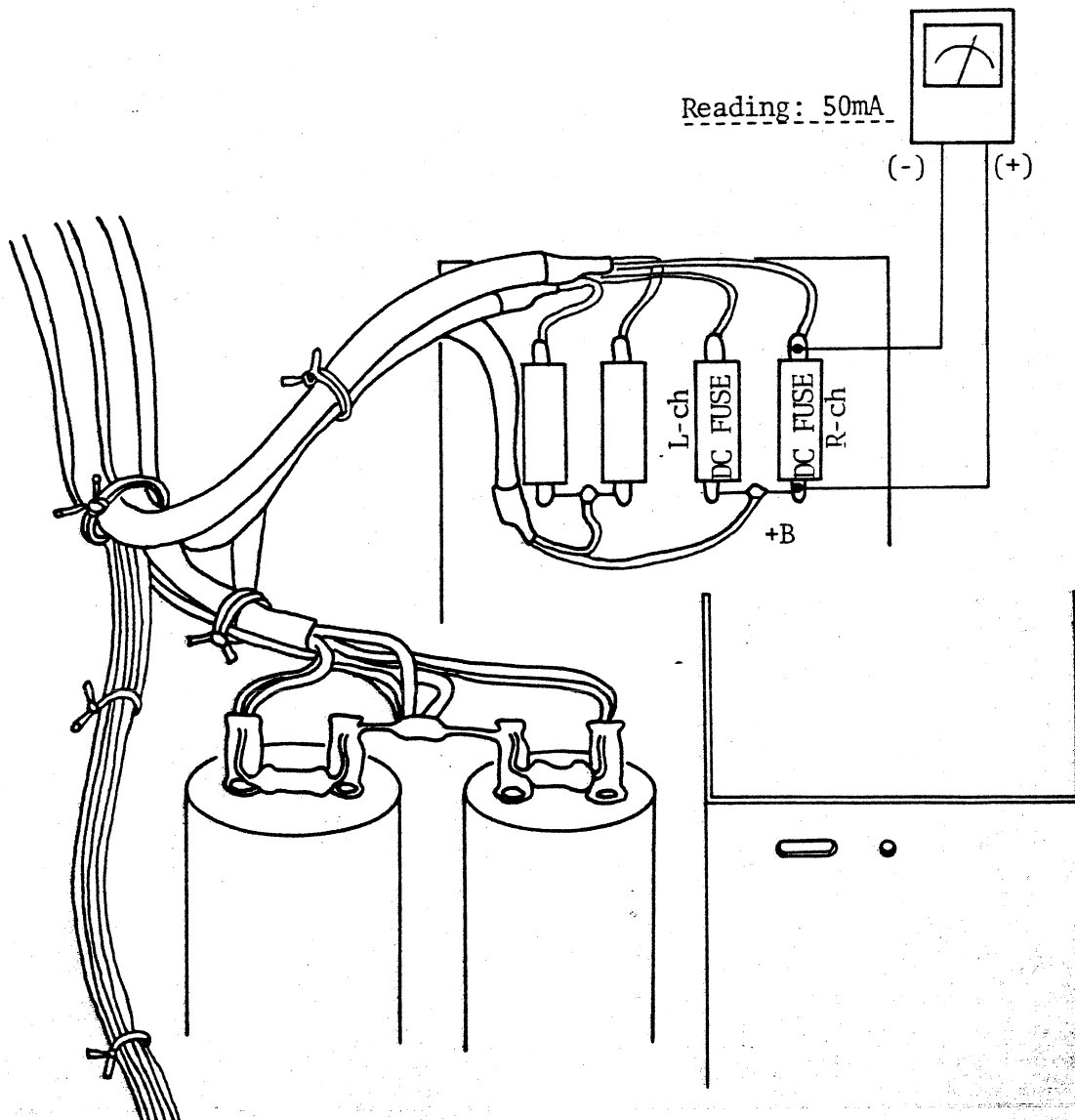
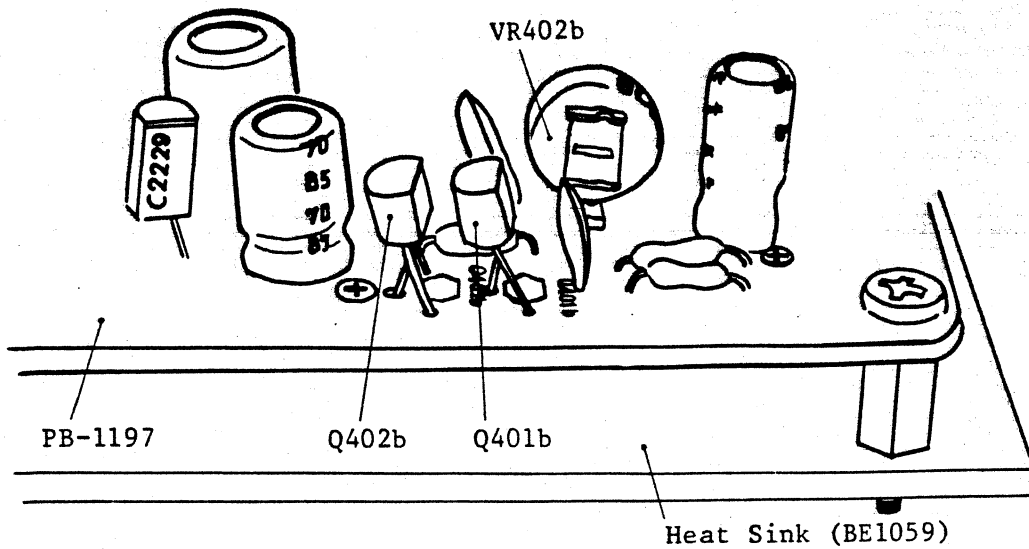

Idle current can be measured by removing the two DC Fuses for L-ch and R-ch. Connect an amperemeter (full scale 250-300mA) across the fuse holder as depicted. Note that in the case of measuring that for the L-ch, be sure to insert the R-ch fuse in the holder, and vice versa for the R-ch. Adjust VR402a(R-ch) or VR402b(L-ch) to obtain 50mA reading on the amperemeter.

EXPLODED VIEW

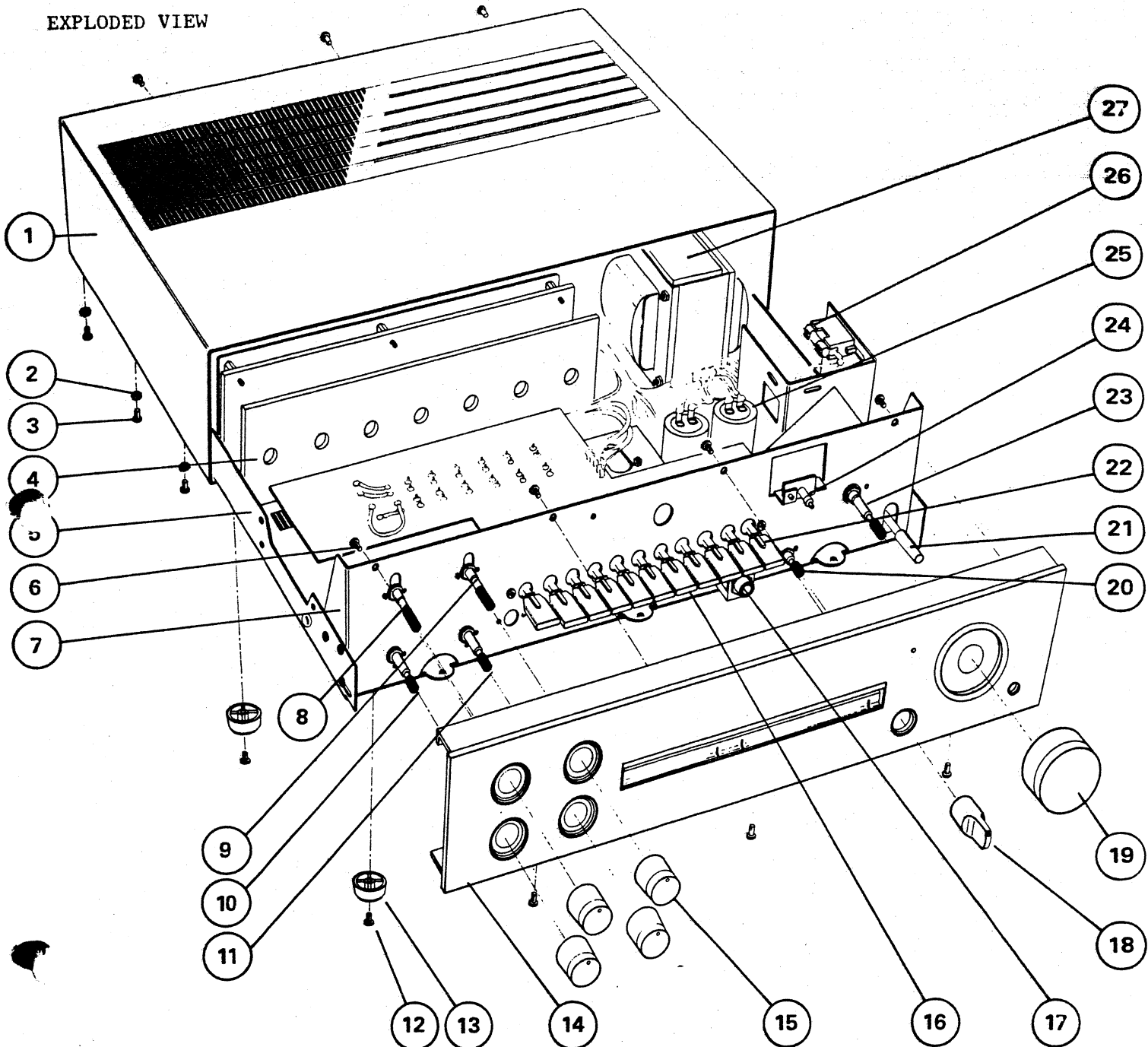

- | | | |
|----------------------------|------------------------------|-------------------------------|
| 1. UG1010 Bonnet (E) (S) | 13. WN0007 Leg | 24. TD0096 LED, SLC25UR (red) |
| UG1016 " (U) | 14. WA1143 Front Panel (U) | 25. CE1438 Electrolytic |
| 2. YWE030B Washer | WA1145 " " (E) (S) | 3300µF 50V |
| 3. YAA30C08 Screw 3x8 | 15. WH1080 Knob Set | 26. BF0079 Fuse 3A (U) |
| 4. BE1059 Heat Sink | 16. WJ1106 Mould Knob | BF0208 " 1A (T) (S) |
| 5. UA1056 Chassis | 17. AJ0016 Headphone Jack | BF0114 " 1.5A (EK) |
| 6. YAA30C08 Screw 3x8 | 18. WH1079 Knob Set | BF0117 " 3A (EZ) |
| 7. UB1048 Sub Panel | 19. WH1081 " " | 27. PT2348 Power Trans. (S) |
| 8. RV0206 Volume 50k-B | 20. RV0250 Volume 250k-MN | PT2349 " " (E) |
| 9. " " " | 21. WJ1080 Mould Knob | PT2350 " " (U) |
| 10. RV0207 Volume 100k-B | 22. SP0106 Push Switch | |
| 11. " " " | SUF 11-key | |
| 12. YJB40A08 Tapping Screw | 23. RV0204 Volume 200k-B x 2 | |
| 4x8 | | |

REMARKS

Capacitors: C.....ceramic, E.....electrolytic, M.....mylar, G.....G capacitor
 S.....styrol, T.....tantalum, Mi.....mica, MP.....MP capacitor
 O.....oil capacitor, TRIM.....trimmer capacitor, AC.....AC capacitor
 BP.....electrolytic Bi-Polar type

Resistors: ±5%, 1/4W, unless specified otherwise

Type: (S)..... model for north European countries
 (U)..... model for U.S.A. and CANADA
 (J)..... model for JAPAN

PB1194

SYMBOL NO.	STOCK NO.	DESCRIPTION	LOCATION
R101ab	RBO224	56K	
102ab	246	470K	
103	210	15K	
104ab	254	1M	
105ab	182	1K	
106ab	234	150K (E) (S)	
107ab	174	470	
108ab	230	100K	
109ab	222	47K	
110ab	180	820	
111ab	184	1.2K	
112ab	220	39K	
113ab	252	820K	
114ab	174	470	
115ab	204	8.2K	
116ab	242	330K	
117ab	254	1M	
118ab	254	1M	
119ab	254	1M	
120ab	254	1M	
121ab	202	6.8K	
122ab	202	"	
123ab	208	12K	
124ab	216	27K	
125	RS1078	680 1/4 F	
126	RBO220	39K	
127ab	234	150K (E) (S)	
Q101ab	TR0125	2SA836	E
102ab	TR0025	2SC1345	E
C101ab	CE0173	3.3μ 25V	E
102	CE0079	220μ 16V	E
103ab	CC0008	150P 50V	C
104ab	CC0003	4.7P 50V	C
105ab	CE0074	10μ 16V	E
106ab	CQ0130	1000P 50V	M
107ab	CQ0130	1000P 50V	M
108ab	CQ0122	6800P 50V	M

SYMBOL NO.	STOCK NO.	DESCRIPTION	LOCATION
109ab	CE0189	0.47μ 50V	E
110ab	CQ0121	0.12μ 50V	M
111ab	CQ0330	3300P 50V	M
112ab	CC0011	470P 50V	C
113ab	CQ0031	0.033 50V	M
114ab	CE0068	47μ 10V	E
115	CE0103	100μ 50V	E
116	CK0145	0.022μ 50V	C
117	CK0159	0.1μF 25V	C
118	CK0159	0.1μF 25V	C
119ab	CC0005	33P 50V	C
SW101	SP0106	Push SW 11key	
102	"	"	
103	"	"	
104	"	"	
105	"	"	
106	"	"	
107	"	"	
108	"	"	
109	"	"	
110	"	"	
111	"	"	

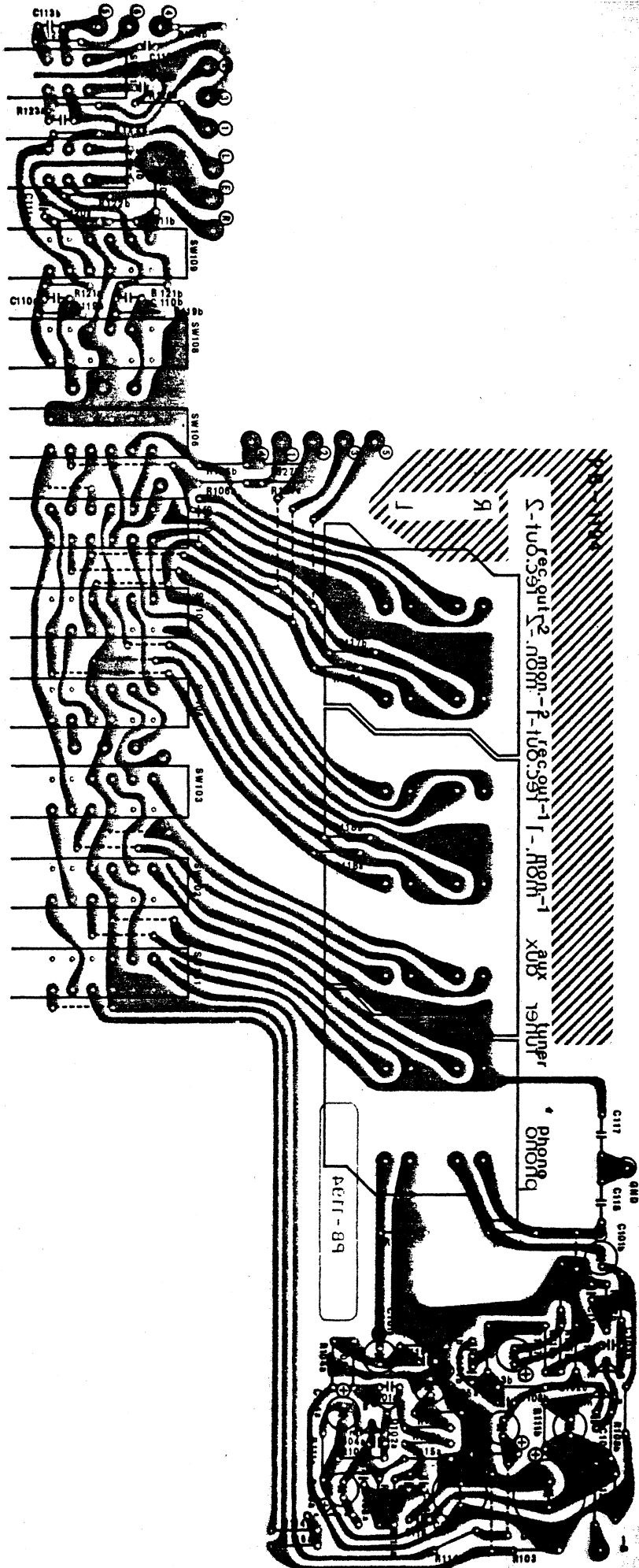

PB1195A

SYMBOL NO.	STOCK NO.	DESCRIPTION	LOCATION
R201	RB0218	33K	
202ab	RB0246	470K	
203	RD0004	1M 1/4	
204	RB0190	2.2K	
205	RD0022	47K 1/4	
206	RB0182	1K	
207	RB0214	22K	
208	RB0198	4.7K	
209	RB0242	330K	
210	RS1092	2.2K F 1/4	
C201	CE0078	100μ 16V E	
202ab	CE0183	1μ 50V E	
203ab	CC0037	5P 25V C	
204ab	CE0173	3.3μ 25V E	
205	CE0095	100μ 35V E	
206	CK0145	0.022μ 50V C	
Q201ab	TR0125	2SA836 E	
202ab	TR0025	C1345 E	
VR201	RV0205	250K MN	
202	RV0204	200K B	

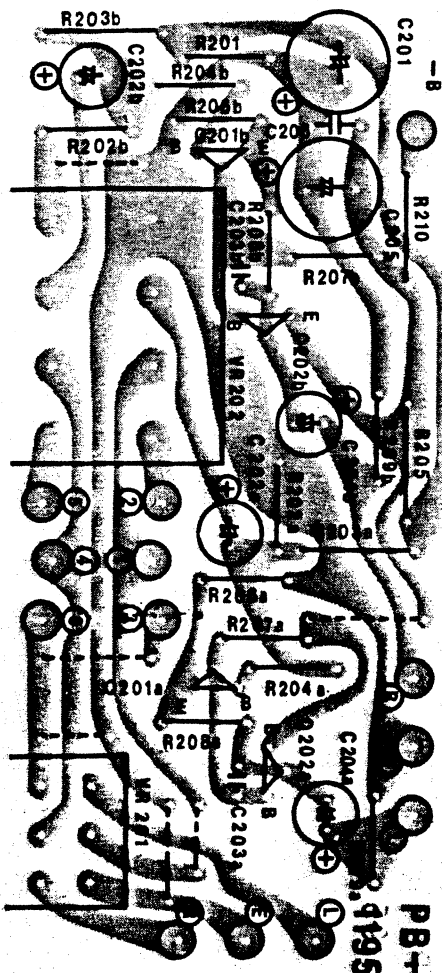

PB1196

SYMBOL NO.	STOCK NO.	DESCRIPTION	LOCATION
R301ab	RB0212	18K	
302ab	186	1.5K	
303ab	186	1.5K	
304ab	212	18K	
305ab	190	2.2K	
306ab	220	39K	
307ab	244	390K	
308ab	182	1K	
309ab	200	5.6K	
310ab	188	1.8K	
311	RS1094	3.3K F 1/4	
C301ab	CQ0124	0.022μ 50V M	
302ab	CQ0130	1000P 50V M	
303ab	CQ0130	1000P 50V M	
304ab	CQ0334	1800P 50V M	
305ab	CQ0334	1800P 50V M	
306ab	CE0173	3.3μ 25V E	
307ab	CC0012	10P 25V C	
308	CE0096	220μ 35V E	
309	CK0145	0.022μ 50V C	
310ab	CE0173	3.3μ 25V E	
Q301ab	TR0125	A836 E	
302ab	TR0125	A836 E	
VR301ab	RV0207	100KB	
302ab	RV0206	50KB	

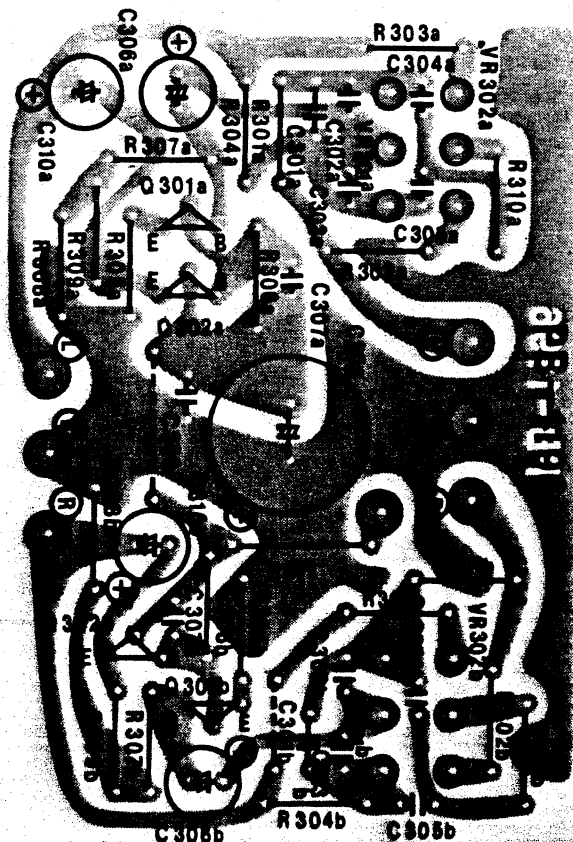

SYMBOL NO.	STOCK NO.	DESCRIPTION	LOCATION	SYMBOL NO.	STOCK NO.	DESCRIPTION	LOCATION
R401ab	RB0194	3.3K		C414	CK0203	0.01μ 500V C	
402ab	RB0206	10K		415	CE0146	220μ 50V E	
403ab	RB0204	8.2K		416	CE0146	220μ 50V E	
404ab	RB0176	560		417	CE0146	220μ 50V E	
405ab	RB0174	470		418	CC0007	100P 50V C	
406ab	RS2525	1.2K 1/2 F		419	CK0203	0.01μ 500V C	
407ab	RB0188	1.8K		Q401ab	TR0193	A942 RAKK	
408ab	RB0196	3.9K		402ab	TR0193	A942 RAKK	
409ab	RB0206	10K		403ab	TR0236	C2229	
410ab	RB0178	680		404ab	TR0146	C1740	
411ab	RB0188	1.8K		405ab	TR0264	C2235	
412ab	RB0150	47		406ab	TR0263	A965	
413ab	RB0150	47		407ab	TR0262	D716	
414ab	RS0074	100 1/2 F		408ab	TR0261	B686	
415ab	RS0074	100 1/2 F		409	TR0125	A836	
416ab	RG0009	0.33		D401ab	TD0002	1N4002	
417ab	RG0009	0.33		402ab	TD0003	1N4003	
418ab	RD0158	10 1W		403	TD0106	S3V40	
419ab	RS2709	10 1W F		?	?	?	
420ab	RS0074	100 1/2 F		406	"	"	
421	RS0074	100 1/2 F		DZ401	TD0065	WZ192	
422	RB0206	10K		ab			
423	RB0182	kK		UC1113		Rear Panel (U)	
424	RS2716	3.3K 1W F		UC1111		" (S)	
425ab	RB0242	330K		UC1112		" (E)	
426ab	RB0150	47		UC1124		" (UC)	
R001	RD0150	4.7K 1W		UB1048		Sub Panel	
L401ab		LUX1004-2 MH		SW001	SP0063	Push SW (U)	
F401	BF0201	Fuse 0.1A (T)			SP0090	" (E)(J)(S)	
	BF0074	Fuse 0.5A (U)		AS0002		DIN CONNE. (E)(S)	
	BF0111	Fuse 0.5A (E)		AH0016		1P Fuse Holder (E)(J)(U)	
C401ab	CE0173	3.3μ 25V E		AH0019		1P Fuse Holder (S)	
402ab	CC0009	220P 50V C		F001	BF0079	3A (U)	
403ab	CE0077	47μ 16V E			BF0014	1.5A (EK)	
404ab	CE0146	220μ 50V E			BF0117	3A (EZ)(J)	
405ab	CE0094	47μ 35V E			BF0208	1A T (S)	
406ab	CC0005	33P 50V C			PT2349	P2349	
407ab	CK0157	0.04μ 25V C				Power Trans(E)	
408ab	CE0098	1μ 50V E			PT2348	P2348 (S)	
409ab	CK0146	0.04μ 50V C			PT2350	P2350 (U)	
410ab	CQ0332	0.039μ 50V M		R003	RD0339	470Ω 1W F	
411ab	CE0102	47μ 50V E		R004	"	470Ω 1W F	
412ab	CE0098	1μ 50V E		C001	CE1430	3300μF 50V E	
413ab	CK0146	0.04μ 50V C		C002	"	3300μF 50V E	
VR402ab	RT0013	Semifix 330Ω-B					

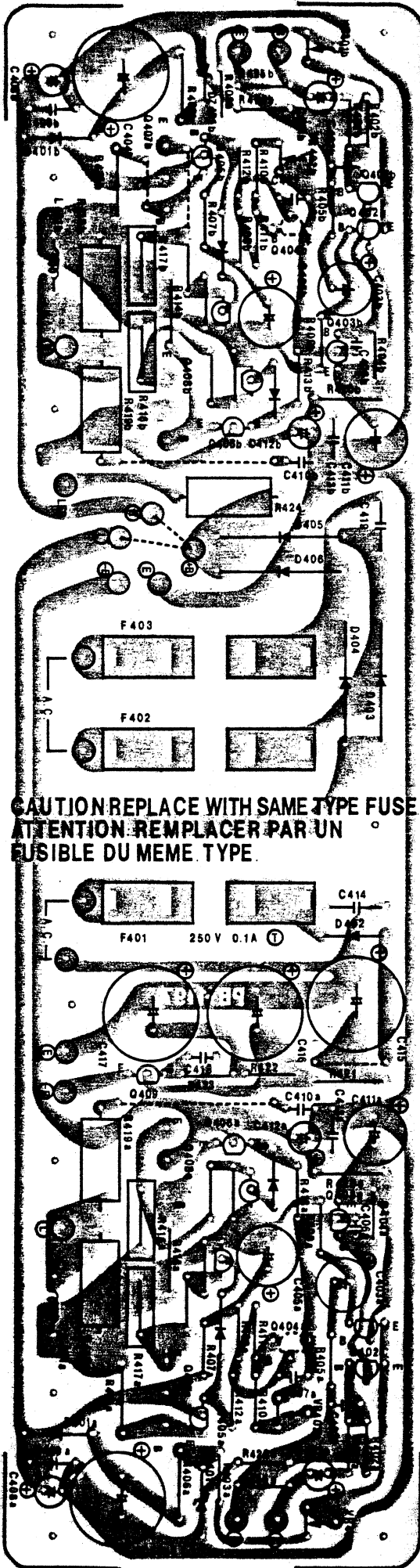

CAUTION REPLACE WITH SAME TYPE FUSE
 ATTENTION REMPLACER PAR UN
 FUSIBLE DU MEME TYPE.

2SC1740 (TR0146)

Absolute Maximum Ratings (Ta = 25°C)

SYMBOL	RATING	UNIT
V _{CBO}	50	V
V _{CEO}	40	V
V _{EBO}	5	V
I _C	100	mA
P _C	300	mW
T _j	125	°C
T _{stg}	-55 - 125	°C

ELECTRICAL CHARACTERISTICS (Ta = 25°C)

SYMBOL	CONDITION	MIN.	TYP.	MAX.	UNIT
BV _{CEO}	I _C =1mA	40	-	-	V
BV _{CBO}	I _C =50uA	50	-	-	V
BV _{EBO}	I _E =50uA	5	-	-	V
I _{CBO}	V _{CB} =30V	-	-	0.5	μA
I _{EBO}	V _{EB} =4V	-	-	0.5	μA
V _{CE(sat)}	I _C /I _B =50mA/5mA	-	-	0.4	V
h _{FE}	V _{CE} /I _C =6V/1mA	120	-	560	-
f _T	V _{CE} =12V, I _E =-2mA	-	180	-	MHz
C _{ob}	V _{CB} =12V, I _E =0, f=1MHz	-	2.0	3.5	pF

2SA942RAK (TR0193)

Absolute Maximum Ratings (Ta = 25°C)

SYMBOL	RATING	UNIT
V _{CBO}	-90	V
V _{CEO}	-90	V
V _{EBO}	-5	V
I _C	-50	mA
I _E	50	mA
P _C	300	mW
T _j	125	°C
T _{stg}	-55 - 125	°C

ELECTRICAL CHARACTERISTICS (Ta = 25 ±15°C)

SYMBOL	CONDITION	MIN.	MAX.	UNIT
I _{CBO}	V _{CB} =-90V, I _E =0	-	-0.1	μA
I _{EBO}	V _{EB} =-5V, I _C =0	-	-0.1	μA
h _{FE}	V _{CE} =-6V, I _C =-2mA	280	700	-
V _{CE(sat)}	I _C =-10mA, I _B =-1mA	-	-0.4	V
C _{ob}	V _{CB} =-10V, I _E =0, f=1MHz	-	5.0	pF
NF	V _{CE} =-6V, I _C =-0.1mA R _g =10k ohms, f=100Hz	-	6.0	dB

2SB686/2SD716 (TR0261/TR0262)

Type No.	V _{CEO} (V)	I _C (A)	P _C (W)	h _{FE}	V _{CE(sat)} MAX			f _T TYP. (MHz)		
					V _{CE} (V)	I _C (A)	I _B (A)			
2SB686 /2SD716	100	6	60	55 - 160	5	1	2.0	4	0.4	10/12

2SA836 (TR0125), 2SC1345 (TR0025)

Type No.	V _{CEO} (V)	I _C (mA)	P _C (mW)	h _{FE}	f _T (MHz)	Condition		NF (dB)	Condition		
						V _{CE} (V)	I _C (mA)		V _{CE} (V)	I _C (mA)	f (Hz)
2SA836	-55	-100	200	160 to 800	200	-12	-2	1	-6	-0.1	1k
2SC1345	50	100	200	250 to 1200	230	12	2	1	6	0.1	1k

2SA965 (TR0263)

Absolute Maximum Ratings (Ta = 25°C)

SYMBOL	RATING	UNIT
V _{CB0}	-120	V
V _{CEO}	-120	V
V _{EBO}	-5	V
I _C	-800	mA
I _E	800	mA
P _C	900	mW
T _j	150	°C
T _{stg.}	-55-150	°C

ELECTRICAL CHARACTERISTICS (Ta = 25°C)

SYMBOL	CONDITIONS	MIN.	TYP.	MAX.	UNIT
I _{CB0}	V _{OB} = -120V, I _E = 0	-	-	-100	nA
I _{EBO}	V _{EB} = -5V, I _C = 0	-	-	-100	nA
V _{(BR)CEO}	I _C = -10mA, I _B = 0	-120	-	-	V
V _{(BR)EBO}	I _E = -1mA, I _C = 0	-5	-	-	V
h _{FE}	V _{CE} = -5V, I _C = -100mA	80	-	240	
V _{CE(sat)}	I _C = -500mA, I _B = -50mA	-	-	-1.0	V
V _{BE}	V _{CE} = -5V, I _C = -500mA	-	-	-1.0	V
f _T	V _{CE} = -5V, I _E = -100mA	-	120	-	MHz
C _{ob}	V _{CB} = -10V, I _E = 0, f = 1MHz	-	-	30	pF

2SC2235 (TR0264)

Absolute Maximum Ratings (Ta = 25°C)

SYMBOL	RATING	UNIT
V _{CB0}	120	V
V _{CEO}	120	V
V _{EBO}	5	V
I _C	800	mA
I _E	800	mA
P _C	900	mW
T _j	150	°C
T _{stg}	-55 - 150	°C

ELECTRICAL CHARACTERISTICS (Ta = 25°C)

SYMBOL	CONDITIONS	MIN.	TYP.	MAX.	UNIT
V _{CB0}	V _{CB} = 120V, I _E = 0	-	-	100	nA
I _{EBO}	V _{EB} = 5V, I _C = 0	-	-	100	nA
V _{(BR)CEO}	I _C = 10mA, I _B = 0	120	-	-	V
V _{(BR)EBO}	I _E = 1mA, I _C = 0	5	-	-	V
h _{FE}	V _{CE} = 5V, I _C = 100mA	80	-	240	
V _{CE(sat)}	I _C = 500mA, I _B = 50mA	-	-	1.0	V
V _{BE}	V _{CE} = 5V, I _C = 500mA	-	-	1.0	V
f _T	V _{CE} = 5V, I _E = 100mA	-	120	-	MHz
C _{ob}	V _{CB} = 10V, I _E = 0, f = 1MHz	-	-	30	pF

2SC2229 (TR0236)

Absolute Maximum Ratings (Ta = 25°C)

SYMBOL	RATINGS	UNIT
V _{CB0}	200	V
V _{CEO}	150	V
V _{EBO}	5	V
I _C	50	mA
I _E	-50	mA
P _C	800	mW
T _j	150	°C
T _{stg}	-55 - 150	°C

ELECTRICAL CHARACTERISTICS (Ta = 25°C)

SYMBOL	CONDITIONS	MIN.	TYP.	MAX.	UNIT
I _{CB0}	V _{CB} = 200V, I _E = 0	-	-	0.1	μA
I _{EBO}	V _{EB} = 5V, I _C = 0	-	-	0.1	μA
h _{FE}	V _{CE} = 6V, I _C = 10mA	70	-	240	
V _{CE(sat)}	I _C = 10mA, I _B = 1mA	-	-	0.5	V
V _{BE(sat)}	I _C = 10mA, I _B = 1mA	-	-	1	V
f _T	V _{CE} = 30V, I _E = -10mA	-	120	-	MHz
C _{ob}	V _{CE} = 10V, I _E = 0, f = 1MHz	-	3.5	5	pF

Silicon Rectifier Diode
S3V40(TD0106)

I_O (A)	V_{RM} (V)	I_{FSM} (A)	P_{RSM} (W)	T_j ($^{\circ}C$)	V_F (V) MAX.	I_R (μA) MAX. at V_{RM}	V_Z (V) MIN.
3.5	400	120	---	+150	1.05	5	---

Zener Diode
WZ-192(TD0065)

ZENER VOLTAGE V_Z (V)			OPERATING RESISTANCE R_d (Ω)		REVERSE CURRENT I_R (μA)	
MIN.	MAX.	@ I_Z (mA)	MAX.	@ I_Z (mA)	MAX.	@ V_R (V)
18.4	20.1	5	20	5	1	16

Silicon Rectifier Diodes

1N4002/1N4003(TD0002/TD0003)

	1N4002	1N4003	UNIT
Maximum Peak Reverse Voltage	100	200	V
Maximum Input Voltage(RMS)	70	140	V
Maximum DC Reverse Voltage	100	200	V
Maximum Output Current(ave.)	1.0		A
Surge Current	30		A
Maximum Forward Voltage Drop	1.1		V
Maximum Full-Load Reverse Current	30		μA
DC Reverse Current	5.0(25 $^{\circ}C$), 50.0(75 $^{\circ}C$)		μA
Reverse Recovery Time	20		μS
Capacitance	15		pF
Thermal Resistance	50		$^{\circ}C/W$
Operating Temperature	-65 ~ +175		$^{\circ}C$
Storage Temperature	-65 ~ +175		$^{\circ}C$

L-2 SPECIFICATIONS

Power Output:	33W/33W (8 ohms, both channels driven)		
Total Harmonic Distortion:	no more than 0.03% (8 ohms, 33W/ch, both ch. driven)		
Rated I.M.:	no more than 0.06% (8 ohms, 33W/ch, 60Hz : 7kHz = 4 : 1)		
Frequency Response:	15Hz ~ 60kHz (within -1dB)		
Input Sensitivity & Input Impedance:	PHONO	2.5mV	50k ohms
	TUNER	145mV	50k ohms
	AUX	145mV	50k ohms
	MONITOR-1	145mV	50k ohms
	MONITOR-2	145mV	50k ohms
Signal-to-Noise Ratio: (input short-circuited)	PHONO	better than 84dB (IHF-A weighted, 10mV)	
	TUNER	better than 90dB (IHF-A weighted)	
	AUX	better than 90dB (IHF-A weighted)	
	MONITOR-1	better than 90dB (IHF-A weighted)	
	MONITOR-2	better than 90dB (IHF-A weighted)	
Residual Noise:	no more than 1mV		
Tone Control:	LUX NF type (100Hz \pm 11dB, 10kHz \pm 10dB)		
Filter:	High Cut	7kHz (-6dB/oct.)	
	Subsonic	25Hz (-6dB/oct.)	
Channel Separation:	PHONO	better than 60dB	
	AUX	better than 70dB	
Additional Features:	Tape Monitor (dual), Tape Dubbing (dual), Loudness Control, Mode Selector, Speaker Terminals (A, B), DIN Connector (E-type, S-type only)		
Dimensions:	438(W) x 289(D) x 105(H) (17-1/4" x 11-3/8" x 4-1/8") (including Legs, Rear Protrusions and Knobs)		
Weight:	Net	7.5kgs (16.5 lbs.)	
	Gross	9.0kgs (19.8 lbs.)	

Specifications and appearance design subject to change without notice.

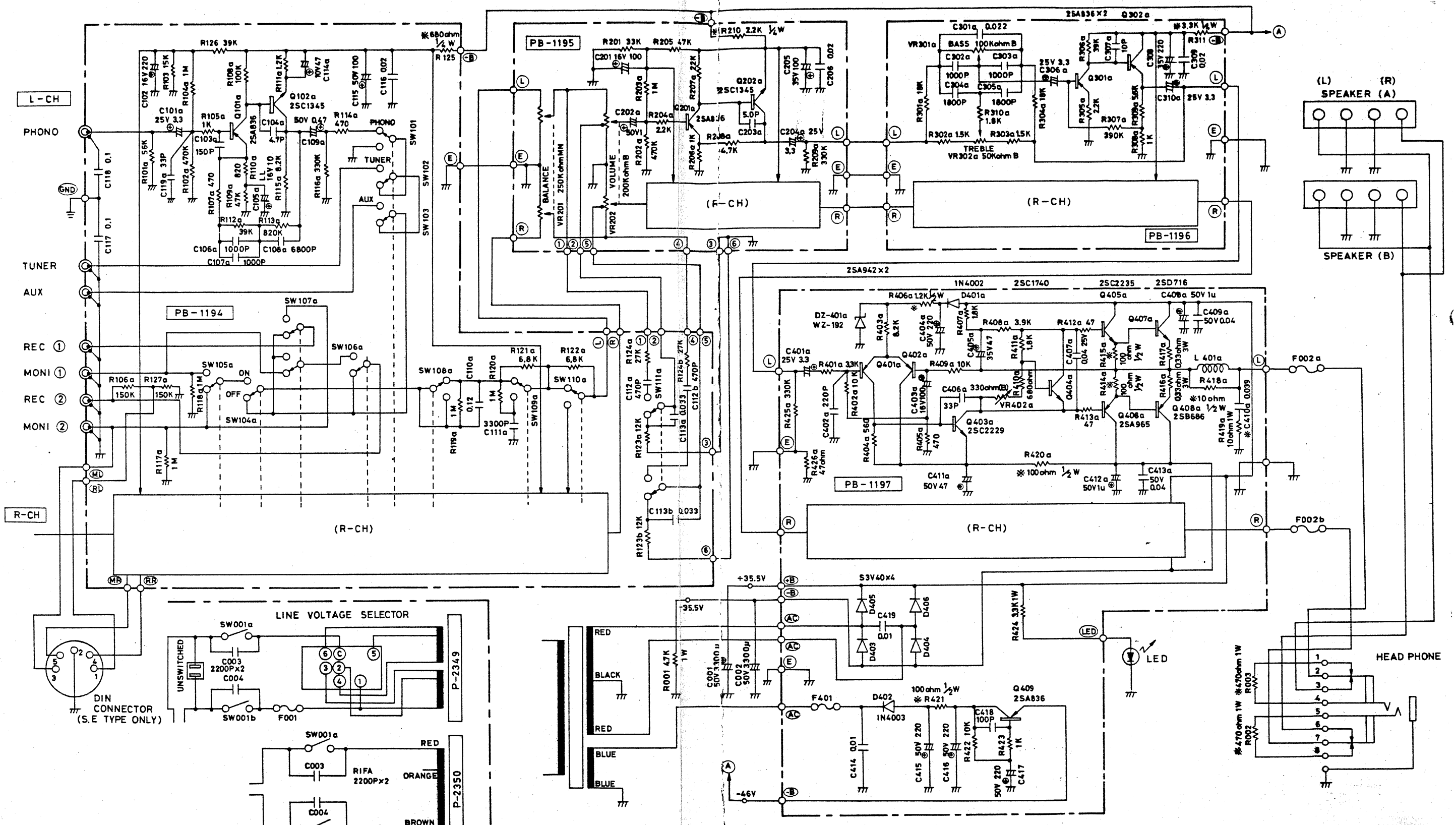

Note: SW 101 PHONO INPUT SELECTOR
 SW 102 TUNER INPUT SELECTOR
 SW 103 AUX
 SW 104 MONITOR
 SW 105 MONITOR 1, 2
 SW 106 DUBBING 1-2
 SW 107 DUBBING 2-1
 SW 108 SUBSONIC
 SW 109 HIGH CUT
 SW 110 MODE
 SW 111 LOUDNESS

*----FLEME PROOF TYPE

SW 001 POWER SW
 SW 501 SPEAKER A.
 SW 502 SPEAKER B.

	J	U	S	E
F 001	3A	3A	1A	3A / 1.5A
F 002 _{ab}	3A	3A	3.15A	3A
F 4 01	0.5A	0.5A	100mA	0.5A